

Die genauen Masse der verschiedenen Pendellängen u.s.w. sind aus der Pendelliste zu entnehmen

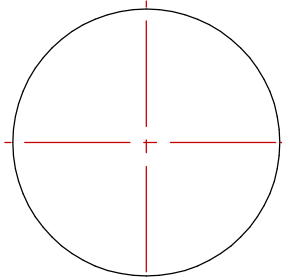

14 Tage Halbstunden Schlagwerk; Federzug; Pendel; Grahamgang; 3 Hämmer hinten; Stabgong

14 day movement with 1/2 hour strike; key wound; pendulum; dead beat escapement; 3 hammers behind; rods gong

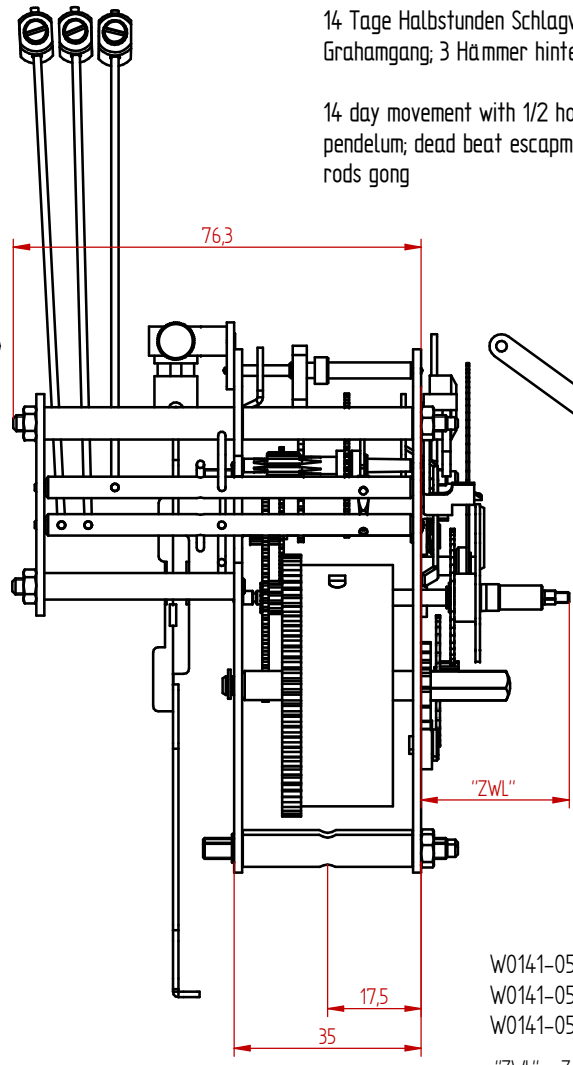

W0141-050 = 33,1 mm  
W0141-053 = 53,1 mm  
W0141-051 = 27,6 mm

"ZWL" = Zeigerwerkstänge; Lengt centershaft

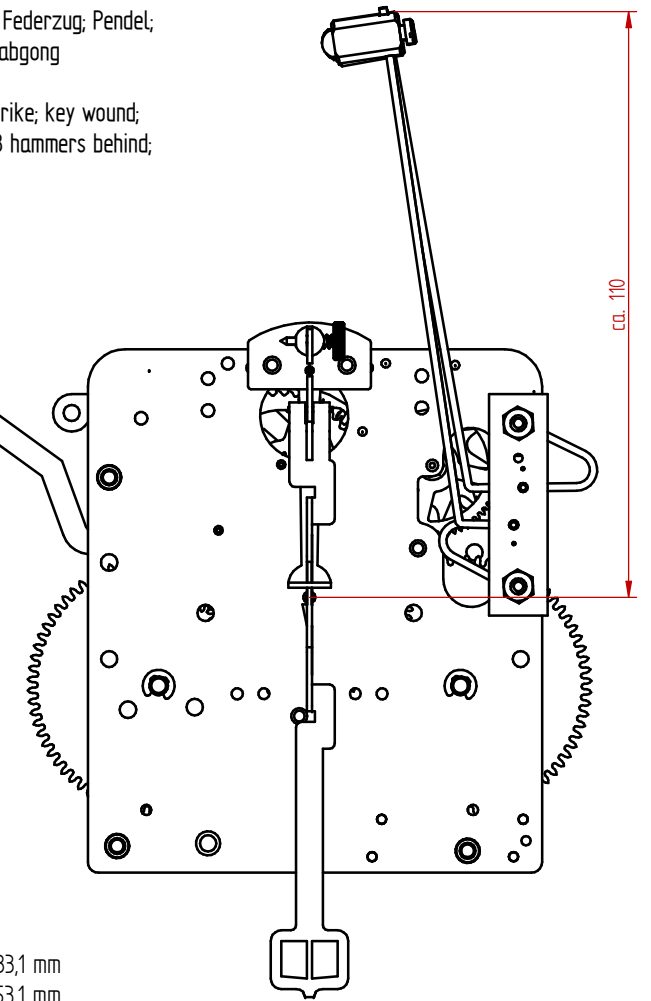

Hermle Werk  
W0141-050

 78559 Gosheim		Masse ohne Toleranzangabe DIN 2768 f	Werkstück- kanten DIN 6784	Maßstab : 1:1	Gew.: 0,000 kg
		Datum Name Bear. 02.04.2019 HMetzger Gepr. Norm		Einbauzeichnung  W0141-050	
Zust. Änderung Datum Nam.					